

IC-PNEUMATIC

Pneumatic Tire Lift Trucks
Diesel

CMP40
CMP45
CMP50S

8,000 lbs 4000 kg
9,000 lbs 4500 kg
10,000 lbs 5000 kg

CMP40/45/50S

M Series

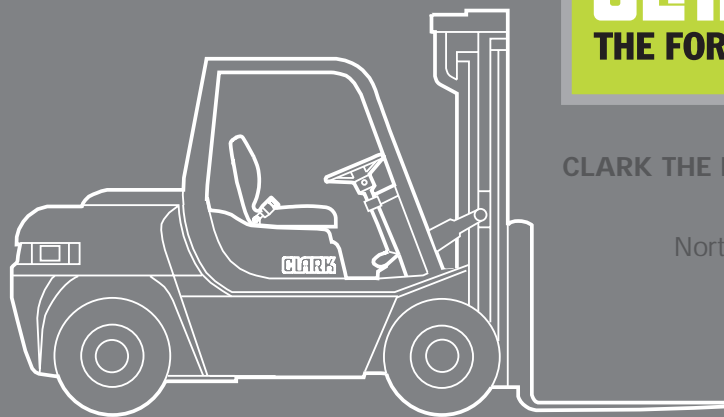

CLARK THE FORKLIFT

North America

Germany

Korea

w w w . c l a r k m h c . c o m

For corresponding data see Specification Chart.

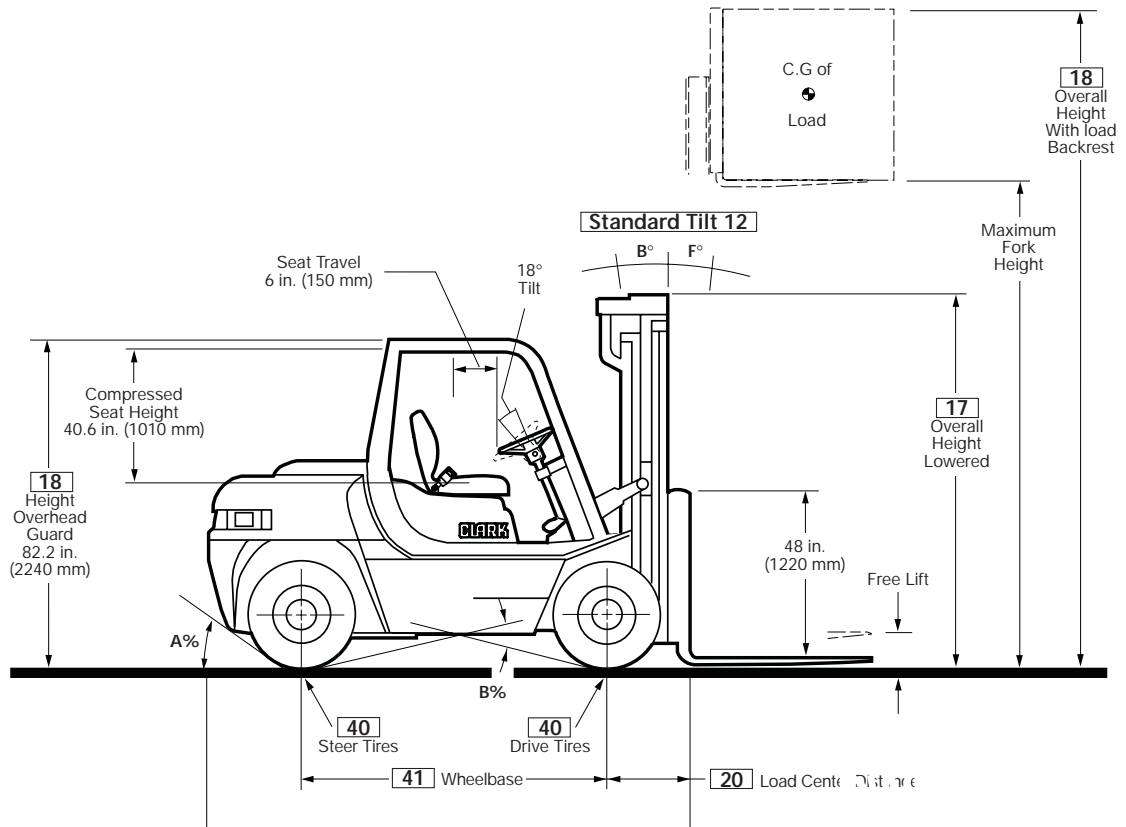

CMP40/45/50S

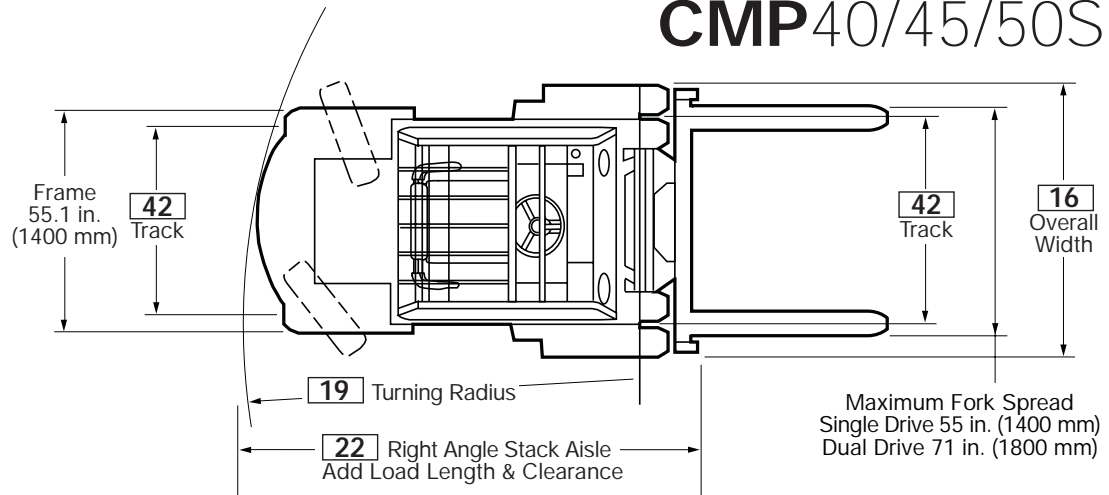

Upright Table

Maximum* Fork Height	Overall Height Lowered	Free Lift	
		in	mm
Standard			
130	3300	94.7	2405
Triple Stage			
177	4500	92	2335
		63	1600

* For overall height raised with load backrest, add 48 in. (1220 mm) to maximum fork height.

Grade Clearance

Model	A%	B%
CMP 40	80	38
CMP 45	67	38
CMP 50S	63	38

Tilt Specifications

Upright MFH(in / mm)	Tilt -B°/ F°
Standard Upright thru 145 in (3683 mm)	10°/ 8°
Triple Stage Upright thru 197 in (5000 mm)	6°/ 4°

Dual Drive Tire Option

CMP 40/45 Dual Drive Tires	Overall Width with Dual Drive
7.50 x 15 in., 12 ply rating	74.8 in. (1900 mm)
71 in. (1800 mm) wide carriage is supplied with dual drive equipped trucks.	

Notes:
1 See Upright Table.
3 Engines rated per SAE J1349.

SPECIFICATIONS

2 Specifications are given for the truck with the standard upright noted in line 10.

General Information	1	Manufacturer		Clark	Clark	Clark	
	2	Model	Manufacturer's Designation	CMP40	CMP45	CMP50S	
	3	Load Capacity	lbs (kg)	8000 (4000)	9000 (4500)	10,000 (5000)	
	4	Load Center	Fork Face Load CG	in (mm)	24 (500)	24 (500)	24 (500)
	5	Drive Unit	Type	Diesel	Diesel	Diesel	
	6	Operator Type		Rider Counterbalanced	Rider Counterbalanced	Rider Counterbalanced	
	7	Tire Type		Pneumatic	Pneumatic	Pneumatic	
	8	Wheels (x=driven)	Front/Rear	2x / 2	2x / 2	4x / 2	
Basic Dimensions	9	Upright ^{1,2}	Maximum Fork Height, Full Capacity	in (mm)	145 (3680)	145 (3680)	145 (3680)
	10		Lift Height (preferred standard upright)	in (mm)	130 (3300)	130 (3300)	130 (3300)
	11		Free Lift	in (mm)	3.9 (100)	3.9 (100)	3.9 (100)
	12	Upright Tilt	Back/Forward (See Tilt Specifications)	degrees	10 / 8	10 / 8	10 / 8
	14	Fork	Std. Fork Size (T x W x L)	in (mm)	2x5x42 (50x127x1067)	2x5x42 (50x127x1067)	2x6x48 (50x152x1220)
	15	Overall Dimensions	Length to Fork Face	in (mm)	121.6 (3090)	123.2 (3130)	124.8 (3170)
	16		Width over drive axle	in (mm)	61 (1550)	61 (1550)	74.8 (1900)
			Height, Upright Lowered	in (mm)	94.7 (2405)	94.7 (2405)	94.0 (2385)
			Height, Upright Extended		180 (4570)	180 (4570)	180 (4570)
	18		Height, overhead guard	in (mm)	88.2 (2040)	88.2 (2040)	87.8 (2230)
	19	Turning Radius		in (mm)	111.4 (2830)	113 (2870)	114.2 (2900)
	20	Load Center Distance	Center of Drive Axle to Fork Face	in (mm)	22.4 (570)	22.4 (570)	22.8 (580)
	22	Right Angle Stack Aisle	Add Load Length and Clearance	in (mm)	134.6 (3420)	135.8 (3450)	137 (3480)
	Performance ^{1,3}	23	Stability	According to ASME/DIN		Yes	Yes
24		Speeds	Travel Speed, Max w/ Load	mph (kph)	12.9 (20.8)	12.9 (20.8)	12.5 (20.1)
25			Travel Speed, Max w/o Load	mph (kph)	13.7 (22.0)	14.0 (22.5)	13.2 (21.2)
			Speed on grade				
			5%, loaded	mph (kph)	8.2 (13.2)	8.1 (13.0)	8.2 (13.2)
			10%, loaded	mph (kph)	4.6 (7.4)	4.4 (7.1)	4.6 (7.4)
			15%, loaded	mph (kph)	3.3 (5.3)	2.7 (4.3)	2.9 (4.7)
26		Lift Speeds, Loaded/Empty	Standard upright	fpm (ms)	95/102 (.48/.52)	90/102 (.46/.52)	87/102 (.44/.52)
28			Triple Stage upright	fpm (ms)	95/102 (.48/.52)	90/102 (.46/.52)	87/102 (.44/.52)
29		Lower Speeds, Loaded/Empty	All uprights	fpm (ms)	93/93 (.47/.47)	93/93 (.47/.47)	93/93 (.47/.47)
30		Drawbar Pull, Maximum	With Load	lbs (N)	7400 (32910)	7365 (32760)	7620 (33980)
31		Without Load	lbs (N)	2965 (13180)	2900 (12890)	3255 (14475)	
32	Gradeability	At 1 mph (1.6 kph) with load (low range)	%	34.7	32.6	27.3	
		Maximum with/without load	%	37.7 (21.4)	34.2 (20.1)	31.7 (20.9)	
Weights ¹	34	Service weight	lbs (kg)	13,205 (5990)	13,890 (5990)	15,210 (6990)	
	35	Axle loading	With Load, Front	lbs (kg)	18,440 (8365)	20,105 (9120)	22,630 (10265)
	36		With Load, Rear	lbs (kg)	2480 (1125)	2600 (1180)	2500 (1135)
	37		W/O Load, Front	lbs (kg)	6095 (2765)	5995 (2720)	6702 (3040)
	38		W/O Load, Rear	lbs (kg)	7110 (3225)	7893 (3580)	8510 (3560)
Chassis	39	Tires	Number, Front/Rear		2 / 2	2 / 2	4 / 2
	40		Size, Front	in	8.25 x 15 - 14 ply rating	8.25 x 15 - 16 ply rating	7.5 x 15 Dual 12 ply rating
			Size, Rear	in	7.00 x 12 - 12 ply rating	7.00 x 12 - 12 ply rating	7.00 x 12 - 12 ply rating
	41	Wheelbase		in (mm)	76.8 (1950)	76.8 (1950)	76.8 (1950)
	42	Track	Front/Rear	in (mm)	51.0/45.3 (1295/1150)	51.0/45.3 (1295/1150)	55.9/45.3 (1420/1150)
	44	Ground Clearance	Minimum at Center of Wheelbase	in (mm)	6.8/9.0 (170/230)	6.8/9.0 (170/230)	5.8/8.0 (150/205)
	46	Service Brake	Type		Wet Disc	Wet Disc	Wet Disc
	47	Parking Brake	Actuation		Lever	Lever	Lever
		Steering	Type		Hydrostatic	Hydrostatic	Hydrostatic
Drive Line	49	Engine	Manufacturer/Model		Perkins / 1004.42	Perkins / 1004.42	Perkins / 1004.42
	51		Rated Output ²	HP/kW @ rpm	82/61 @ 2300	82/61 @ 2300	82/61 @ 2300
			Torque	lb-ft/Nm @ rpm	210/284 @ 1400	210/284 @ 1400	210/284 @ 1400
	52		Speed, max Governed	rpm	2400	2400	2400
	53		Cylinders/Displacement	cu. in.-Liters	4 / 243-4.0	4 / 243-4.0	4 / 243-4.0
	54	Transmission	Manufacturer/Type, Speeds F/R		Powershift, 2 / 2	Powershift, 2 / 2	Powershift, 2 / 2
	57	Hydraulic Pressure	For Attachments	psi (bar)	2000 (137)	2000 (137)	2000 (137)
58	Sound Level	Avg. at Operator's Ear per ASME B56.11.5	dB(A)	80	80	80	

Clark CMP 40/45/50S Series pneumatic tire trucks are suited for wide ranging indoor and outdoor applications in manufacturing, warehousing and distribution operations. They are equipped with 2-speed powershift transaxles and are available with single and dual drive tires. These trucks are supplied with an high level of standard features.

Operator Control & Comfort

The CMP 40/45/50S Series trucks incorporate an isolated operator cell supported on rubber mounts that reduce vibration and sound transmission to the operator seat and controls. Low in-frame steps, 18.7 in. (475 mm) high, enable easy access to the cabin. A rubber floor mat makes footing secure. Seat deck-mounted hydraulic control levers reduce fatigue through minimal required arm movement. Forward/backward movement of the electric directional control lever enables "finger tip" operation of the powershift transaxle; high/low range is selected by lifting/depressing the lever. Two-pedal inch-brake system provides excellent control and comfort. Left pedal is for inch and brake operation, right pedal for brake only.

Safety seat system provides protection in the event of a lateral overturn. The system, proven effective, includes lateral restraints, non-cinching seat belt with retractor and latching seat deck. Separate back and seat cushions are durable and comfortable; seat has 6 in. (150 mm) of front-to-back travel to accommodate small and large operators. Tilt steering wheel can be secured at any position within its range of travel. Rear hinged clamshell hood with gas cylinder assist makes access for daily inspection convenient.

Operator display monitor includes: Indicator lights for engine oil pressure, battery charge, transmission temperature, park brake "on", turn signal indicators and panel test light. Five digit hour meter and analog engine temperature and fuel gauges are provided on the display.

Diesel Engine

Perkins 1004.42, 4.0L 4-cylinder engines have iron block and cylinder head, 5 main bearing crankshaft and an internal dynamic balancer system that smoothes engine vibration. Valve guides, exhaust valve seals and dry type cylinder sleeves are replaceable. New generation design incorporates low smoke, fuel efficient direct fuel injection and manifold type Thermostart system. Vertical exhaust is standard. Engine Accessories/Capacities: Trucks are 12-volt negative ground. Starters are equipped with heavy-duty clutch and anti-restart system. Batteries are 800 CCA at 0°F (-18 °C). All utilize heavy-duty air cleaners with pre-cleaners for added engine protection. Cooling system capacity is 16 qts. (16.9 L). Crankcase capacity is 2 gals. (7.6 L); Fuel tank capacity is 17.4 gal. (66 L). Service Access: Clamshell hood gives full access for inspections and service. Single piece floor panel is removable without tools. Filters are easily serviced and located to prevent spillage. Radiator is accessed, and removed easily, without counterweight or major component removal.

Transaxle

SF45 two-speed powershift transaxle is a single unitized driveline designed for reliability under maximum load and severe operating conditions. The transaxle features electric shift control that provides smooth engagement on start-up and on-the-fly shifts between low and high range. Electric shift control eliminates linkage wear and adjustment. A transmission oil cooler located in the engine radiator extends transaxle life. Full-floating drive axle design adds durability as only torsional forces, not truck loads, are transmitted through the axle shafts. Service is enhanced by a readily accessible transaxle control cover and spin-on, full-flow lubricant filter.

Brakes

Hydraulic-operated wet disc brakes provide excellent brake performance and extended brake life. Brakes can be actuated from either left or right foot pedals. Left foot pedal also provides inching control. Disc/caliper-type parking brake on transmission is left hand-operated, and operator adjustable. Brake system reservoir is easily accessed on the front cowl.

Steering

Heavy fabricated steer axle incorporates an integral double-acting steer cylinder providing equal steering rate. Single-piece steer knuckles supported by tapered roller bearings provide high durability with low maintenance requirements. Full hydrostatic operation reduces mechanical links and eliminates kick-back. The axle is mounted in "silent block" cushion mounts that absorb shock and improve comfort. They require no maintenance.

Hydraulic System

The main hydraulic pump is direct driven by the engine crankshaft, providing reliability and separation from engine heat. Full-flow filter is located in the hydraulic tank providing continuous filtration. Hydraulic tank cover incorporates return line fittings, dipstick, and breather filter connection. Adjustable hydraulic valve eliminates unnecessary oil flow, energy loss and heat generation. Integral-with-frame hydraulic tank dissipates hydraulic oil heat. Fluid capacity 17.1 U.S. gals. (65 L).

Upright Assembly

High visibility two-stage designs and are configured to provide maximum forward visibility. Interlocking rail/nested roller upright design utilizes specially rolled inner rail and channel section outer rails for high strength under heavy load conditions and greater tolerance to unbalanced load conditions. Uprights incorporate negative rail drop feature that enables upright rollers to be easily accessed for adjustment. Shaft type fork carriage incorporates six main rollers and four thrust rollers. Tilt cylinders incorporate spherical bushings at their mounting points to extend seal life by maintaining axial cylinder loads. Hydraulic counterbalance valve prevents improper tilt cylinder operation, flow limiting valves protect against rapid carriage descent in the event of a line failure, and a lowering control regulates lowering speeds. ITA Class III hook type carriages incorporate six main rollers and additional side thrust rollers too prevent binding when handling unbalanced loads. Forks are upset forged and have adjustable locks to maintain desired position. Forks are retained by the load backrest extensions.

Additional Features/Available Equipment

Color is high visibility Clark Green with dark gray operator cell and upright. Wheels are bright white. Operator Manual is permanently attached to truck. Standard features include: 48 in. (1200 mm) high load backrest, recessed towpin, (4) built-in lift eyes, headlights, tail lights, and turn signals. Clark's *Employer's Guide to Material Handling Safety* and operator safety video are provided with truck. Available equipment includes: integral sideshifter, steel cab with heater, rear work light, strobe light, audible alarm, mirrors, auxiliary hydraulic functions and attachments. Contact a Clark representative for additional information.

Notes

Production engines and driveline components may vary in output and/or efficiency by ±10%. The performance shown represents nominal values which may be obtained under typical operating conditions of a machine. Clark products and specifications are subject to change without notice. © Clark Material Handling Company 2001.

ASME and Insurance Classification

Standard truck meets all applicable mandatory requirements of Part II-ASME-B56.1 Safety Standard for Powered Industrial Trucks and Underwriters Laboratories requirements as to fire hazard only for Type D classifications. For further information contact a Clark representative.

For Your Safety

Before operating a lift truck, an operator must:

- **Be trained and authorized**
- **Read and understand the operator's manual**
- **Not operate a faulty lift truck**
- **Not repair a lift truck unless trained and authorized**
- **Have the overhead guard and load backrest extension in place**

During operation, a lift truck operator must:

- **Wear a seat belt**
- **Keep entire body inside truck cab**
- **Never carry passengers or lift people**
- **Keep truck away from people and obstructions**
- **Travel with lift mechanism as low as possible and tilted back**

To park a lift truck, an operator must:

- **Completely lower forks or attachments**
- **Shift into neutral**
- **Turn key off**
- **Set parking brake**
- **Contact your Clark dealer for operator training information.**

North America CMHC

Sales & Marketing HQ
2317 Alumni Park Plaza
Suite 500
Lexington, KY 40517
1-877-66-CLARK
www.clarkmhc.com

Germany CMHE

DE Manufacturing
Rheinstraße 19-23
D-45478
Mülheim an der Ruhr
+49 208-588 (0)
www.clarkmhe.com

Korea CMHA

Changwon Headquarters
& Manufacturing
#40-1, Ungnam Dong
Changwon-City
Kyungnam, Korea 641-290
82-55-260-9001, 9008
www.clarkmhc.co.kr

Seoul Office
Cheongnam Bldg.
13, 16th Floor,
1329-3 Socho-Dong, Socho-Gu
Seoul, Korea 137-070
82-2-2186-6500
www.clarkmhc.co.kr

your authorized CLARK dealer is: